

Parrett Lockdown English work: Week 8

Day 1	Monday 1 st March
Reading	<p>10 mins reading of your reading book</p> <p>You can access extra reading books for the week on: https://www.oxfordowl.co.uk/for-home/find-a-book/library-page/ or Epic Books</p>
Writing	<p>Rhyming Words</p> <p>Developing: Read the Seasons Poem. Try to think of at least one extra word for each season that rhymes, it can be a made-up word if you like. Play the golden river game with an adult at home. Match up the words that rhyme on your worksheet.</p> <p>Secure: Complete developing activity. Write down two of the rhyming words you thought of in your books for each word.</p> <p>Mastery: Complete developing activity. Pick two of your rhyming words. Try to create two sentences that rhyme, just like Max's example. Write them in your books. "Here I am at the beach having a lick of my ice-cream. On my walk, I found a stick."</p>
Phonics	<ol style="list-style-type: none"> 1. Complete your flashcards and revise your tricky words. 2. Reading captions – watch Mrs Brown reading a caption on Twitter/tapestry. Watch what happens when she gets stuck. 3. Read your captions and draw a picture of what you read. Try to do this independently first, before asking for help.

Day 2	Tuesday 2 nd March
Reading	<p>10 mins reading of your reading book</p>
Writing	<p>Find a stick and take it with you on a short walk. See if you can find some interesting things to fasten to your stick. Then use your stick and the things that you have found to talk about where you went on your walk, what you saw and how you felt.</p> <p>Developing: Complete Mrs Brown's sentence starters about your adventure!</p> <p>Secure: Write a description of what you found and did in your book. Use Mrs Brown's example and sentence starters if you need to.</p> <p>Mastery: Write a description of what you found and did in your book. Use Mrs Brown's example and sentence starters if you need to.</p>
Phonics	<ol style="list-style-type: none"> 1. Complete your flashcards and revise your tricky words. 2. Today we are learning a new sound 'ear'. Watch and copy Mrs Brown's actions on Twitter. Write the new sound in your book. Watch: https://www.youtube.com/watch?v=4JSwmP61nXo 3. Can you read Mrs Brown's words? Tick the ones you can sound out and blend. 4. Complete your 'ear' worksheet.

Day 3	Wednesday 3 rd March
Reading	10 mins reading of your reading book
Writing	<p>For the rest of the week you are going to create your own story and book!</p> <p>Planning a new adventure for Max:</p> <p>Developing: You are going to create a new story for Max or a dog you know, but you need to start with a plan! Complete Mrs Brown's planning sheet so you know what happens at the beginning, middle and end of your story!</p> <p>Secure: You are going to create a new story for Max or a dog you know, but you need to start with a plan! Complete Mrs Brown's planning sheet so you know what happens at the beginning, middle and end of your story!</p> <p>Mastery: You are going to create a new story for Max or a dog you know, but you need to start with a plan! Complete Mrs Brown's planning sheet so you know what happens at the beginning, middle and end of your story!</p>
Phonics	<ol style="list-style-type: none"> 1. Complete your flashcards and revise your tricky words. 2. Revise new sound 'ear'. Can you sound out Mrs Brown's questions? Tick the ones you can do. 3. Play picnic on pluto on phonics play, selecting the 'ear' sound.

Day 4	Thursday 4 th March
Reading	Today is World Book Day! Read one of your World Book Day books if you have got one.
Writing	<p>Developing: Write a draft of your own dog adventure using Mrs Brown's story map sheet. Try to write one whole sentence in each box.</p> <p>Secure: Write a draft of your own dog adventure using Mrs Brown's story map sheet. Try to write a full sentence in each box. See if you can challenge yourself and add describing words!</p> <p>Mastery: Write a draft of your own dog adventure using Mrs Brown's story map sheet. Try to write a full sentence in each box. See if you can challenge yourself and add a variety of describing words!</p> <p>After you have finished your story, think about:</p> <ul style="list-style-type: none"> - Are there any letters I think I need to care special care with when writing? - Have I written all the letters on the line? - Are my letters the right size? - Have I made sure to sound out the words I know correctly? <p>Go through your story with an adult, and make a note of what you need to remember when writing it up neatly.</p>
Phonics	<p>Complete your flashcards and revise your tricky words.</p> <ol style="list-style-type: none"> 1. Today we are learning a new sound 'air'. Watch Mrs Brown's actions on Twitter and write the sound in your books. 2. Watch: https://www.youtube.com/watch?v=uZHKK9jnfFQ 3. Complete one phonics play game, selecting the sound 'air'.

Day 5	Friday 5 th March
Reading	10 mins reading of your reading book
Writing	<p>Creating a book in your neatest handwriting. Take your time and remember which letters your adults told you to take special care with from yesterday.</p> <p>Don't forget to write on a line (draw them in pencil as a guide)</p>

	<p>Developing: Write your story from yesterday up neatly using the book you have been given. Create illustrations to support your story. You can also create a front and back cover.</p> <p>Secure: Write your story from yesterday up neatly using the book you have been given. Create illustrations to support your story. You can also create a front and back cover.</p> <p>Mastery: Write your story from yesterday up neatly using the book you have been given. Create illustrations to support your story. You can also create a front and back cover.</p>
Phonics	<p>Complete your flashcards and revise your tricky words.</p> <ol style="list-style-type: none">1. Sound out and read Mrs Brown's sentences, tick the ones you can do.2. Complete your 'air' worksheet.3. Finish off by choosing a game on phonics play to play.

to complete throughout the week whenever you would like. Do not stick in book.

My 3D Shapes Activity Booklet



Name:



3D Shape Colouring

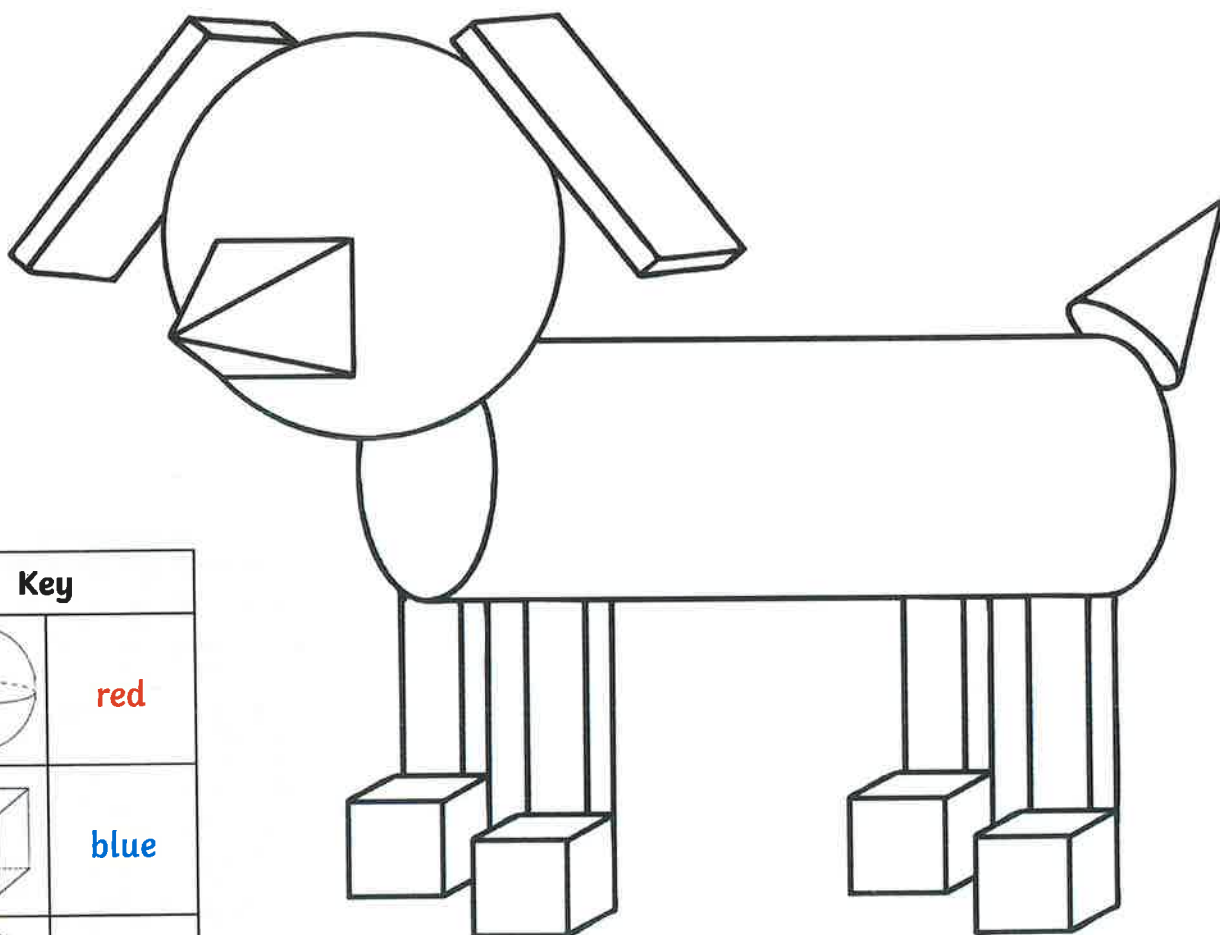

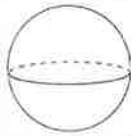
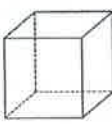
Use the key to colour in the 3D shapes correctly.

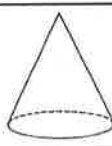
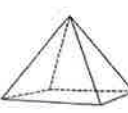

Key	
	red
	blue
	green
	purple
	orange
	yellow

3D Shape Colouring

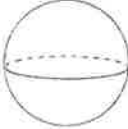
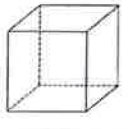
Use the key to colour in the 3D shapes correctly.

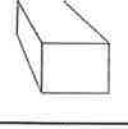
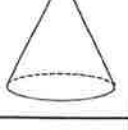
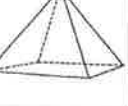
Key	
	red
	blue
	green
	purple
	orange
	yellow

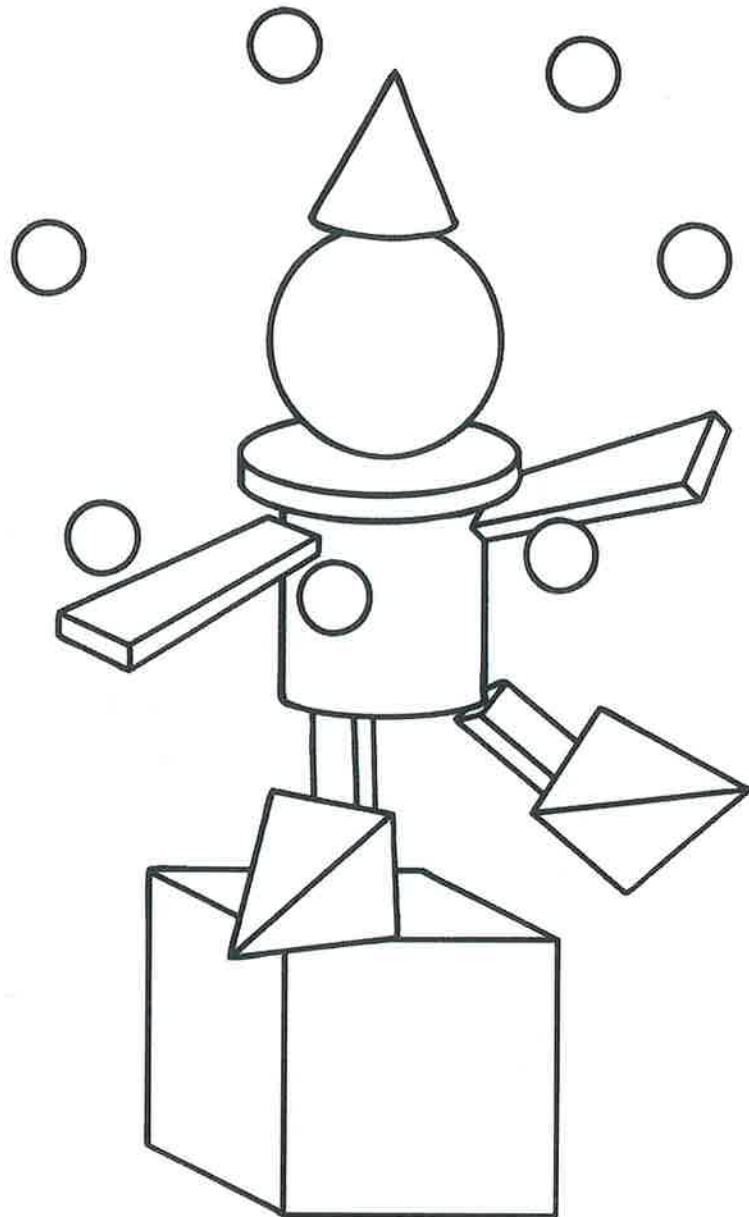

3D Shapes

I Spy and Count to 10

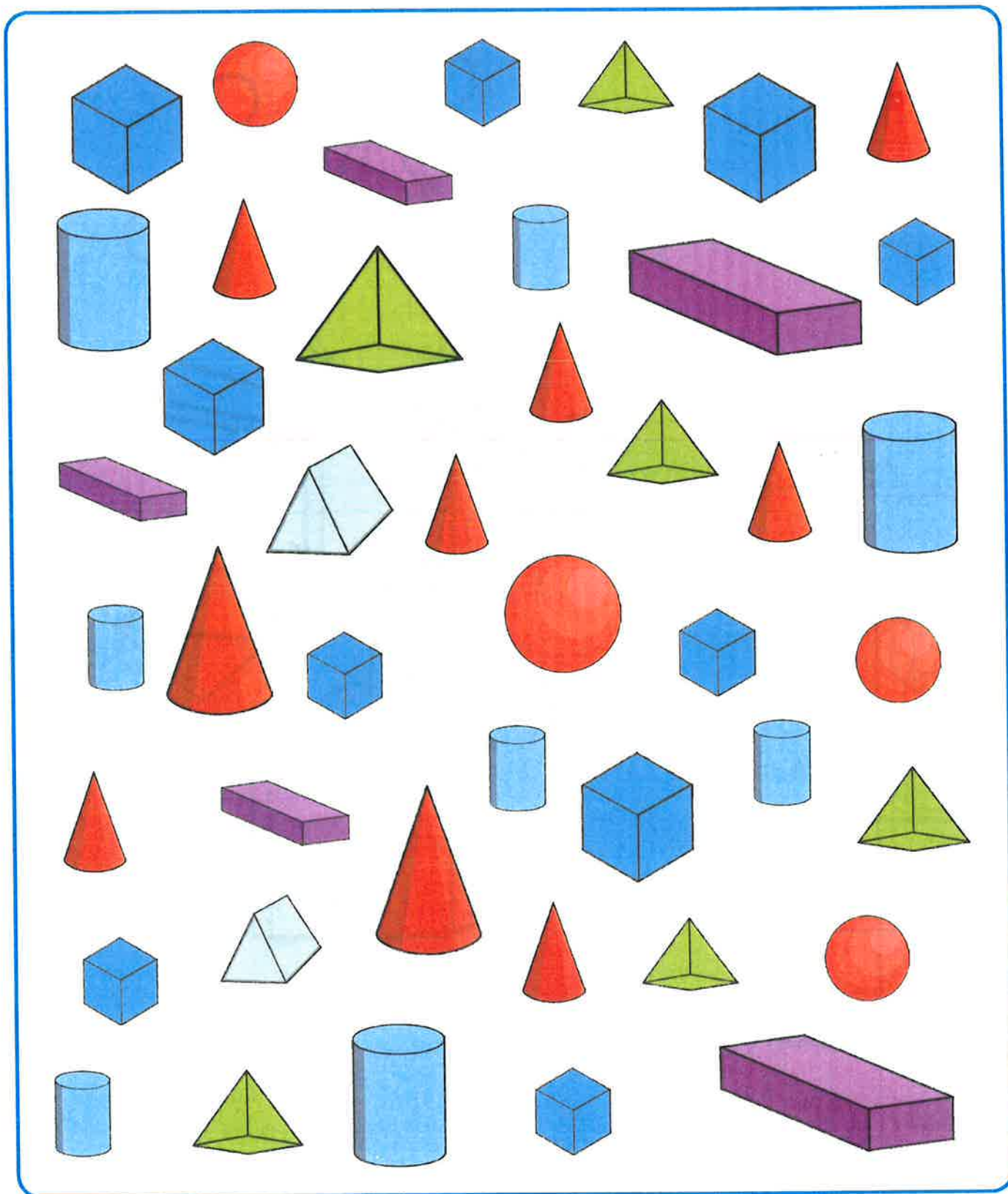

3D Shapes

I Spy and Count to 10 Checklist

Count the number of each type of 3D shape and write the numeral in the box.

cubes

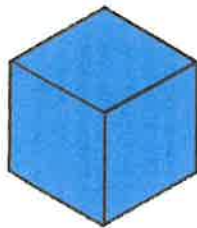

spheres



cuboids

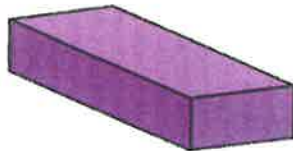

triangular
prisms

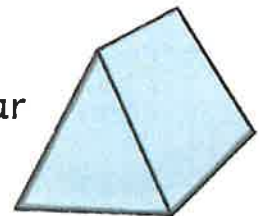

cylinders



pyramids

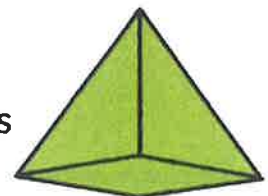

cones



3D Shape Names

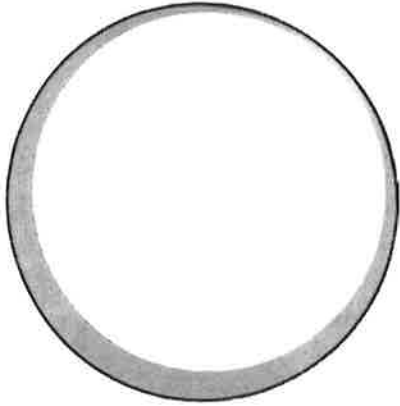

sphere

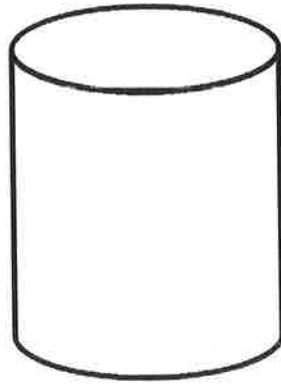

cylinder

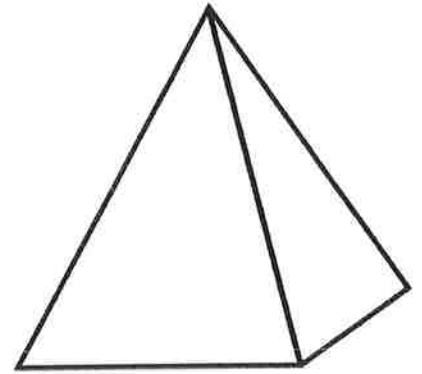

pyramid

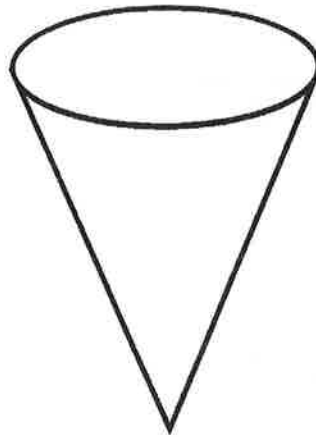

cone

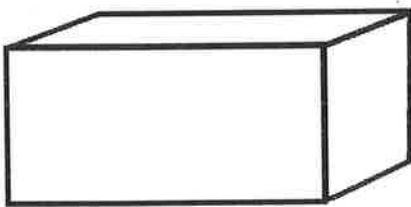

cuboid

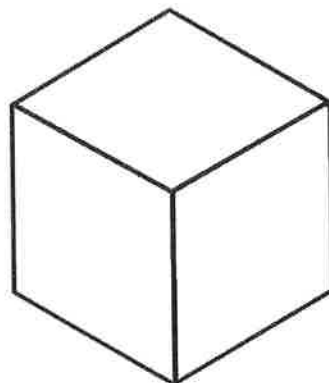

cube

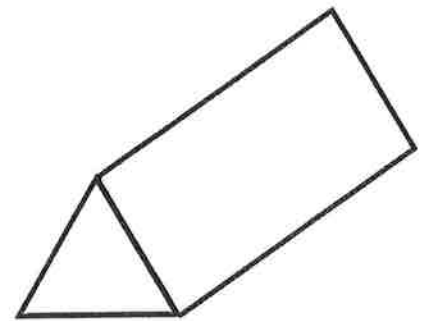

triangular
prism

Cube Shape

Cube

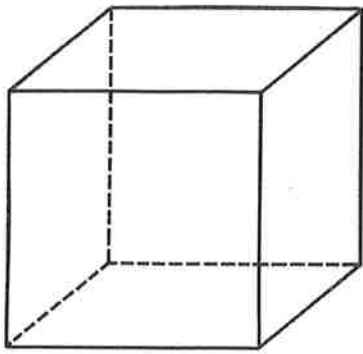

Trace

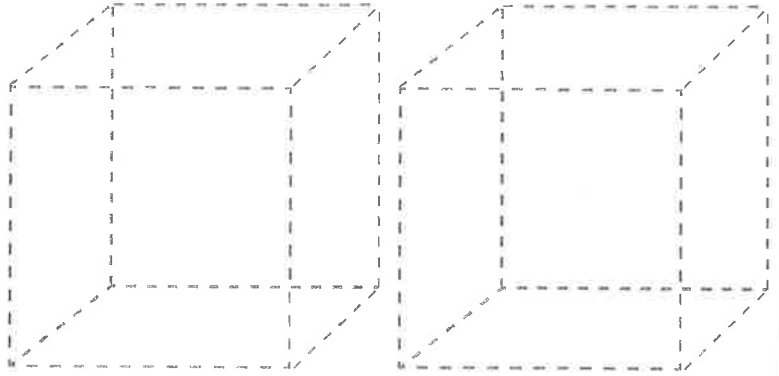

Colour in

CUBE

Colour in all the cubes.

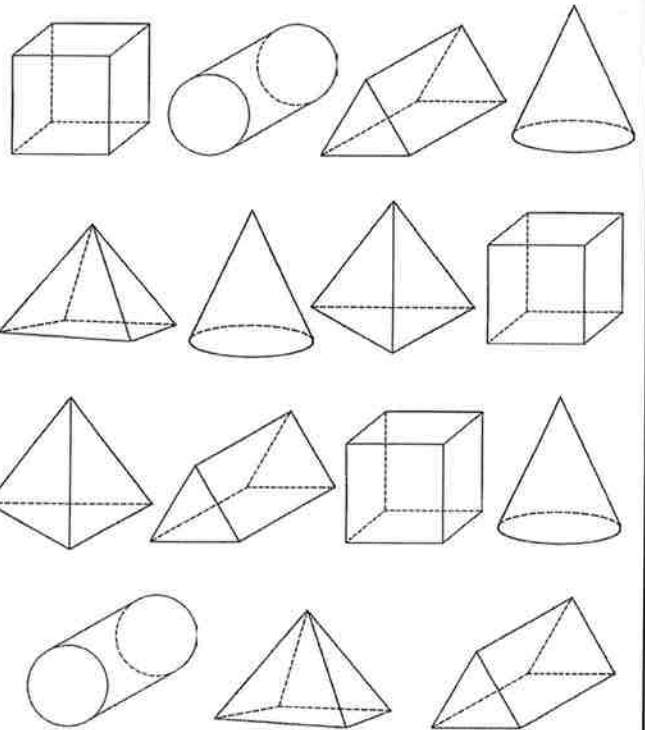

Stick the cubes in the correct size order.



visit [twinkl.com](https://www.twinkl.com)

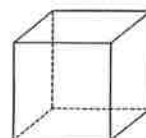
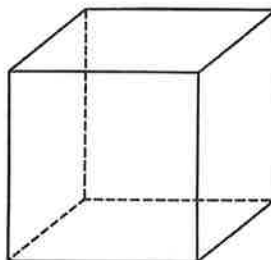
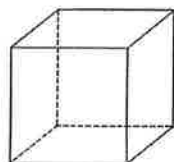

Cylinder Shape

Cylinder

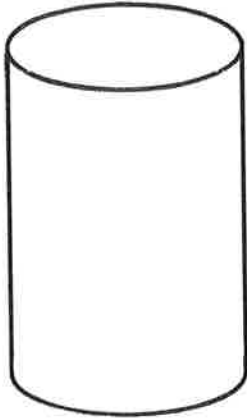

Trace

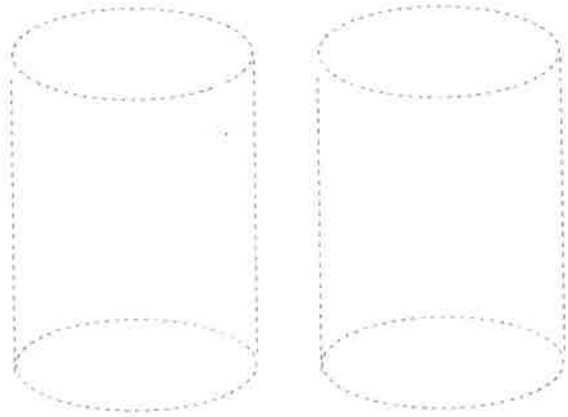

Colour in

CYLINDER

Colour in all the cylinders

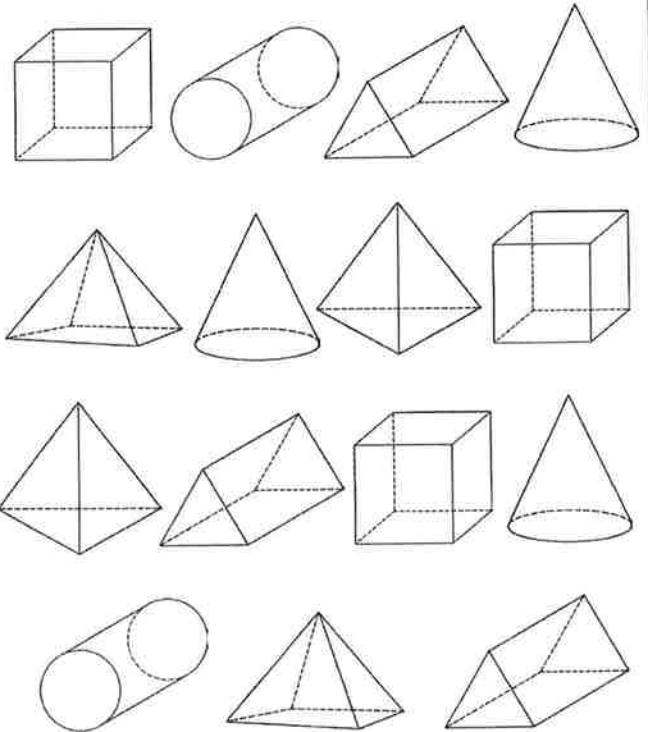

Stick the cylinders in the correct size order.



visit [twinkl.com](https://www.twinkl.com)

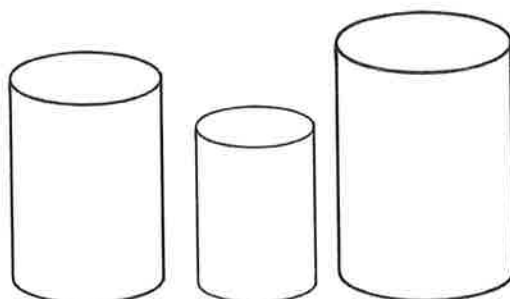

Cone Shape

Cone

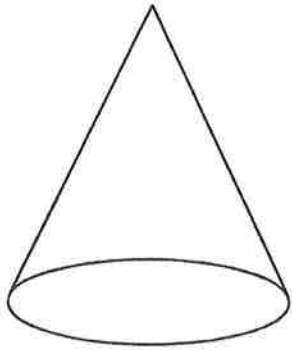

Trace

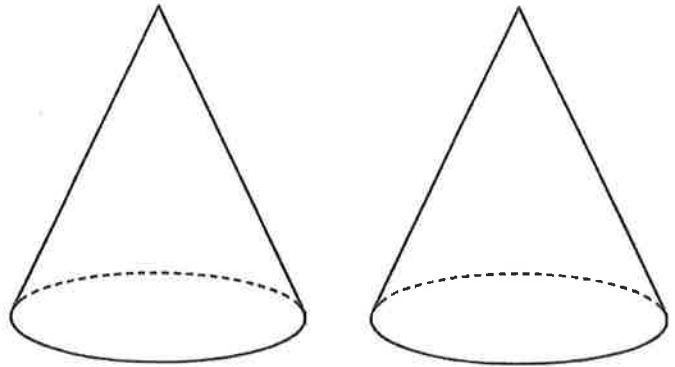

Colour in

CONE

Colour in all the cones.

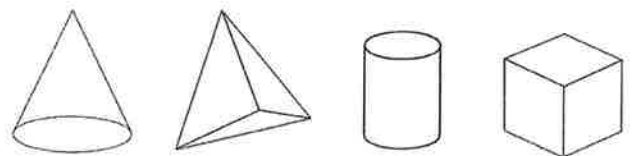
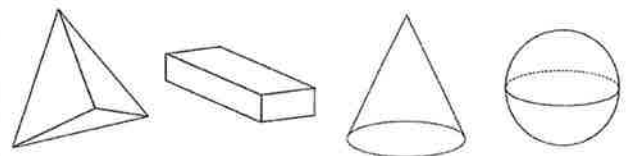
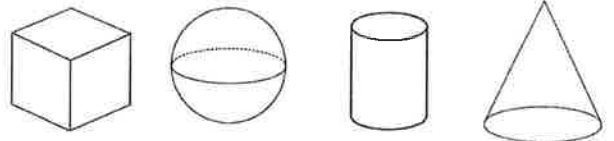
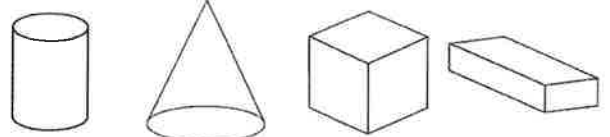

Stick the cones in the correct size order.

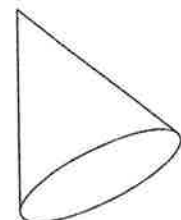
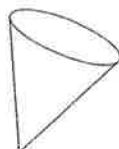
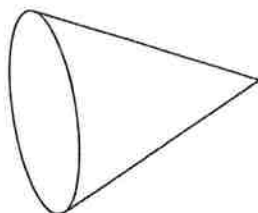

Sphere Shape

Sphere

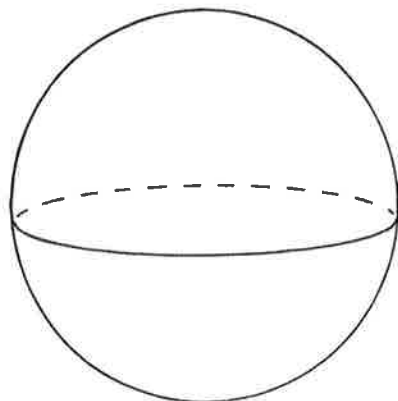

Trace

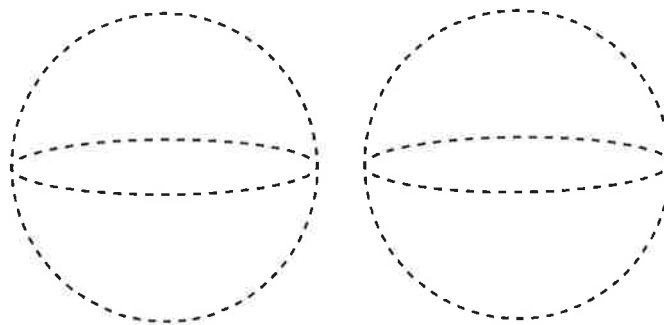

Colour in

SPHERE

Colour in all the spheres.

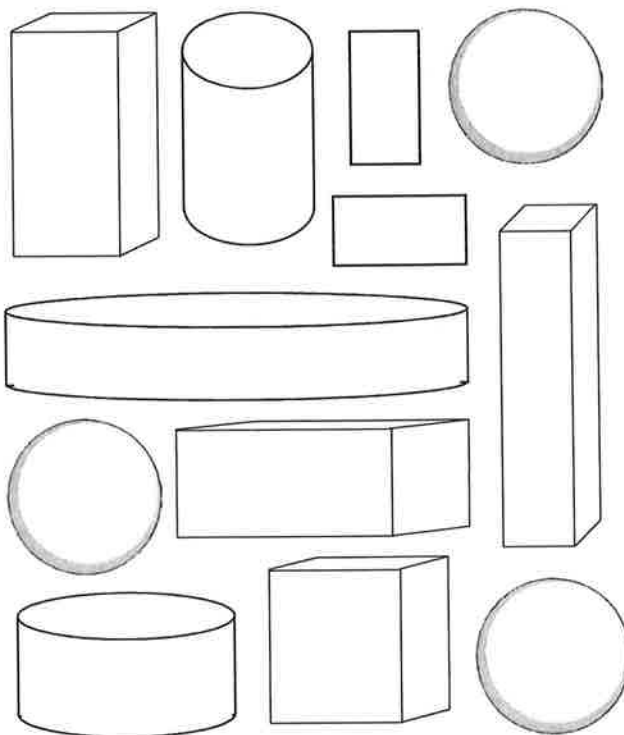

Stick the spheres in the correct size order.



visit [twinkl.com](https://www.twinkl.com)

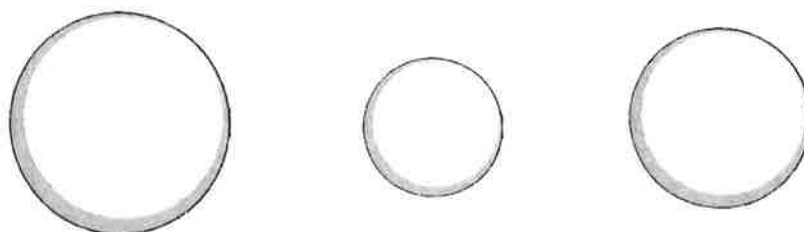

Cuboid Shape

Cuboid

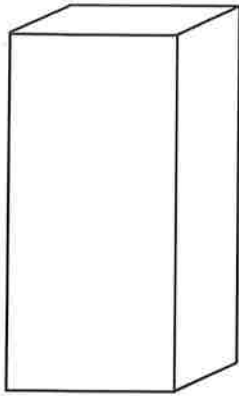

Trace

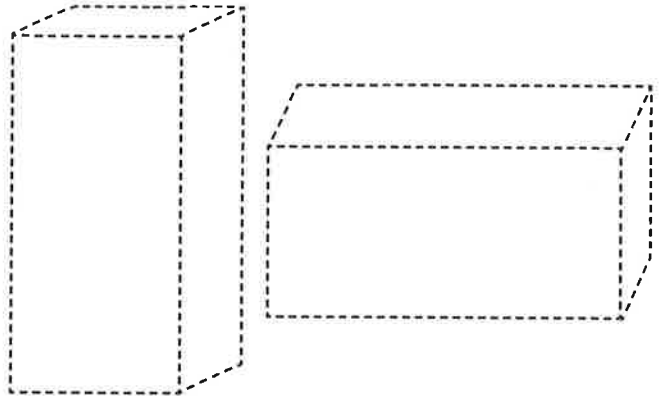

Colour in

CUBOID

Colour in all the cuboids.

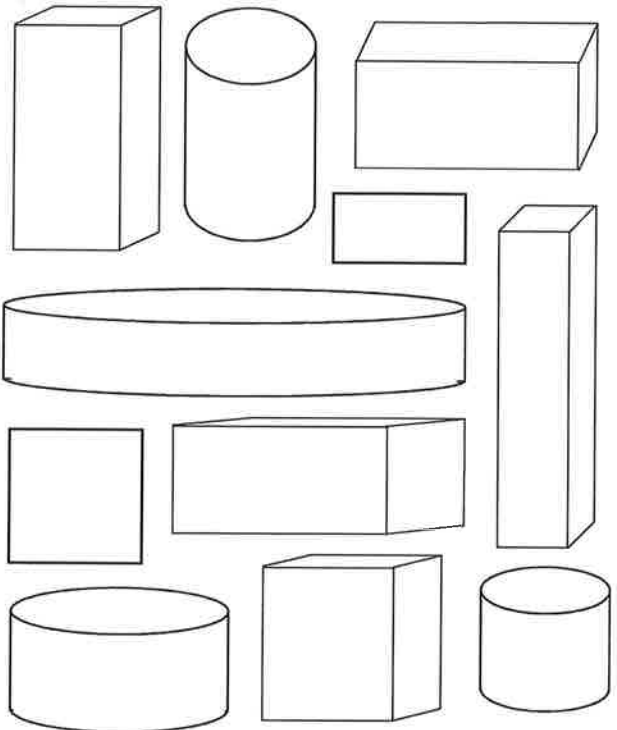

Stick the cuboids in the correct size order.



visit [twinkl.com](https://www.twinkl.com)

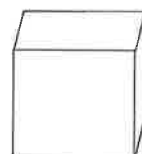
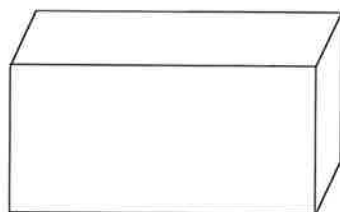
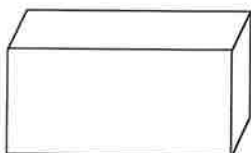

3D Shapes Colouring

Find the shapes and colour them in the correct colour.

Colour the cubes green.

Colour the spheres blue.

Colour the cones red.

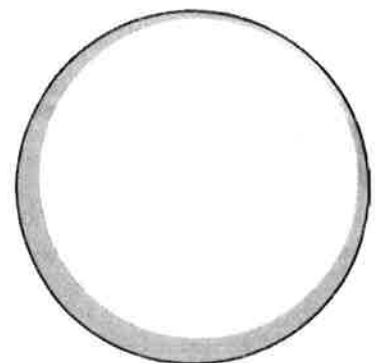
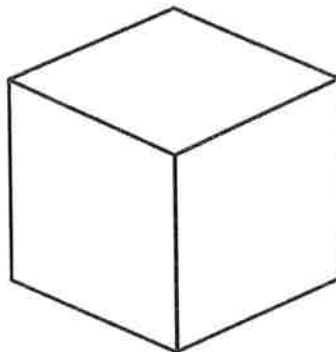
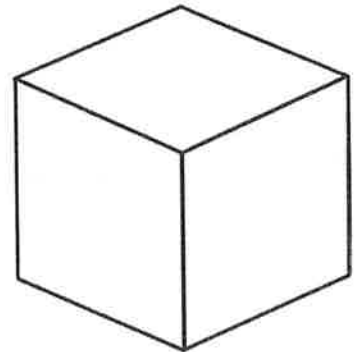
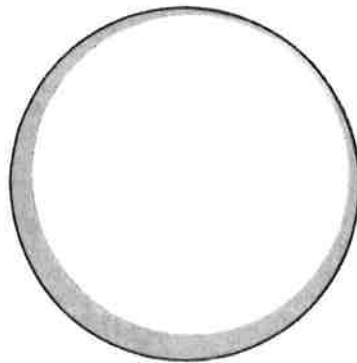
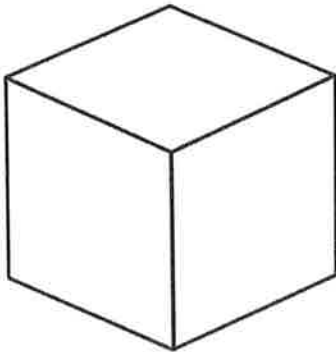
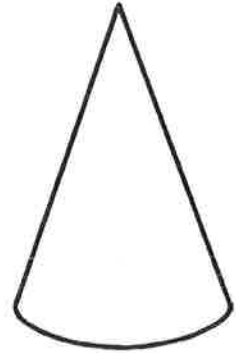
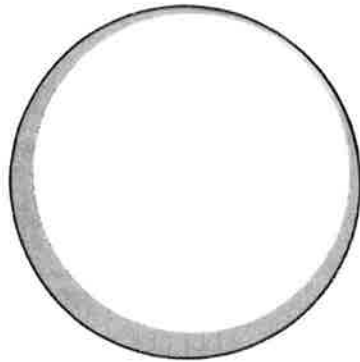
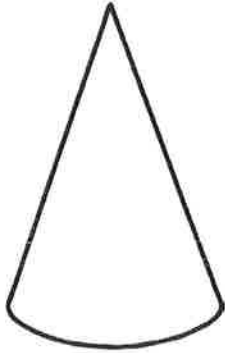

3D Shapes Colouring

Find the shapes and colour them in the correct colour.

Colour the cuboids green.

Colour the cylinders blue.

Colour the pyramids red.

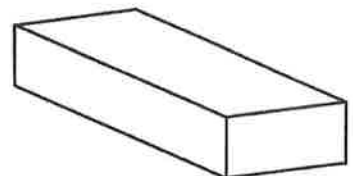
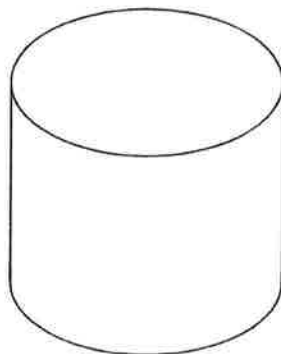
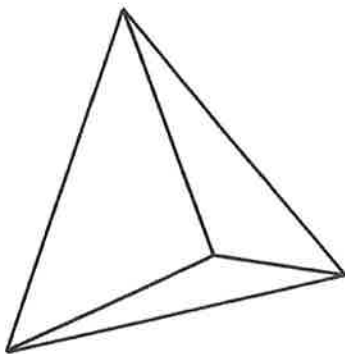
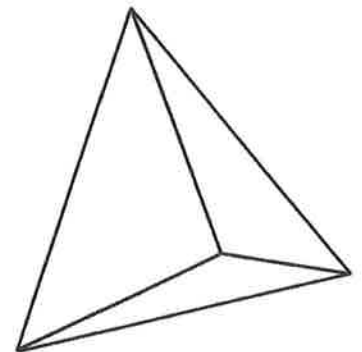
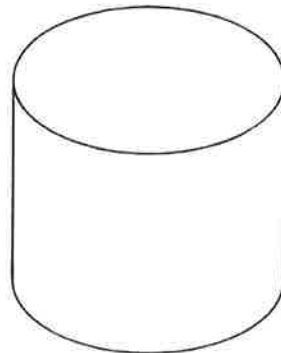
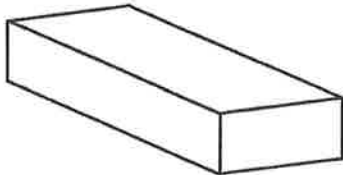
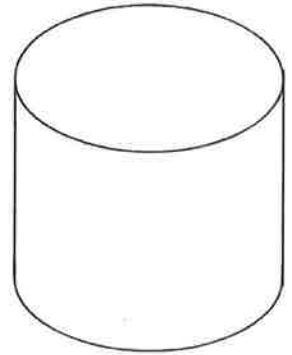
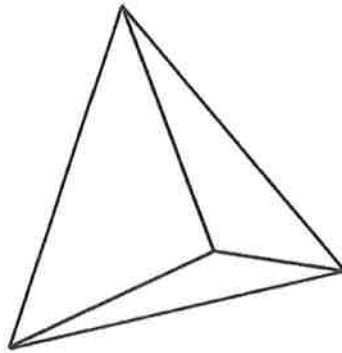
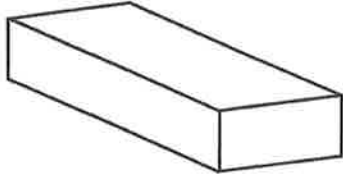

Flashcards to help recognise + remember 3D shapes

sphere

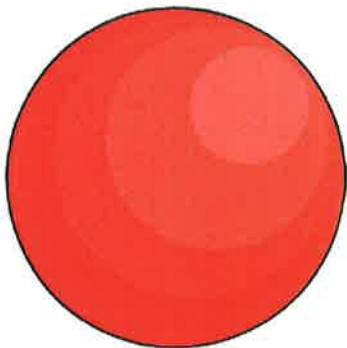

cube

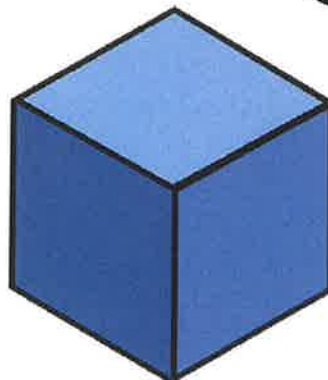

pyramid

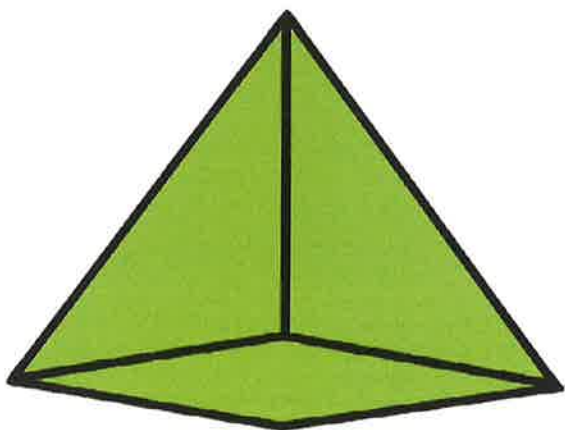
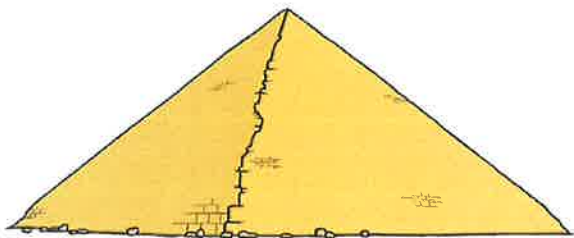

rectangular prism



cylinder

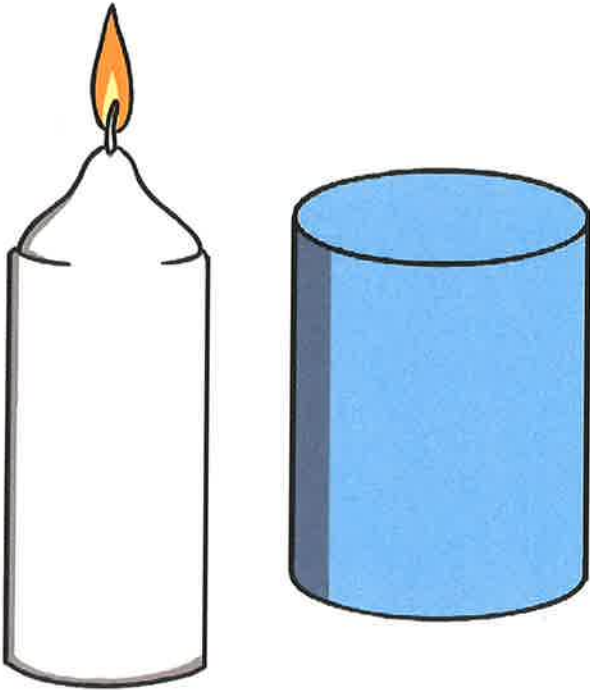

twinkl.com

cone

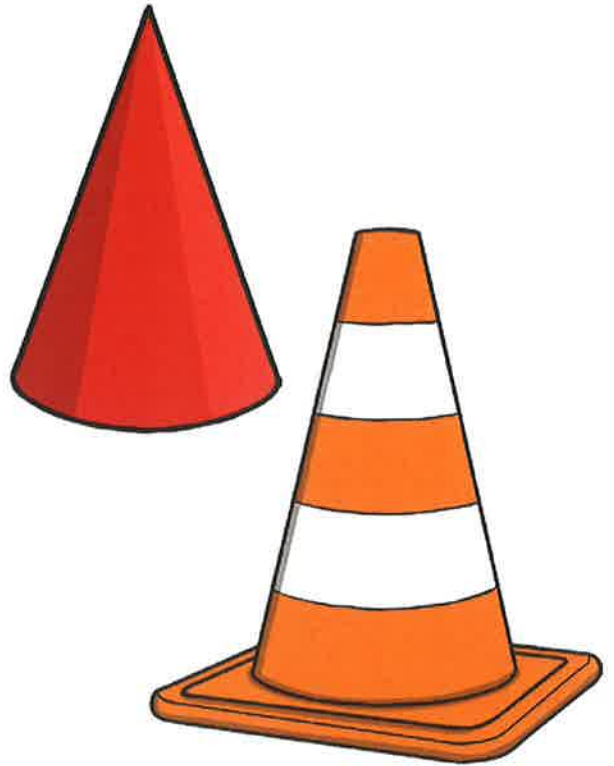

twinkl.com

triangular prism

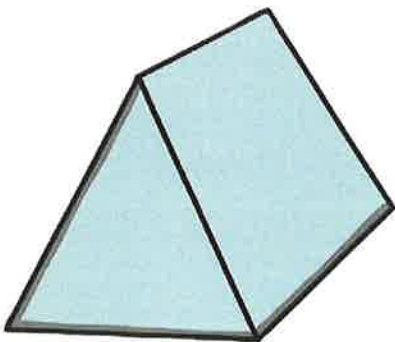

twinkl.com

Monday 1st March - Developing

Stripy Scarves





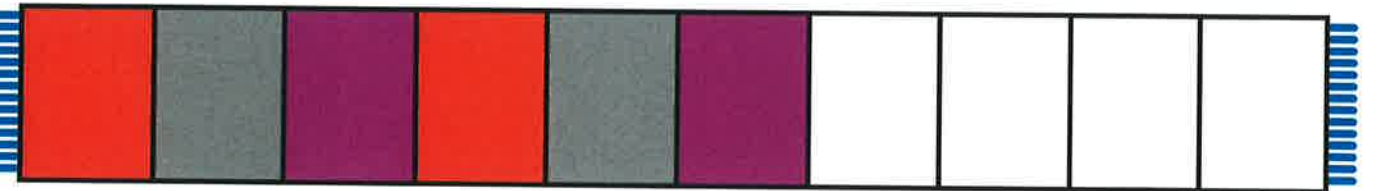
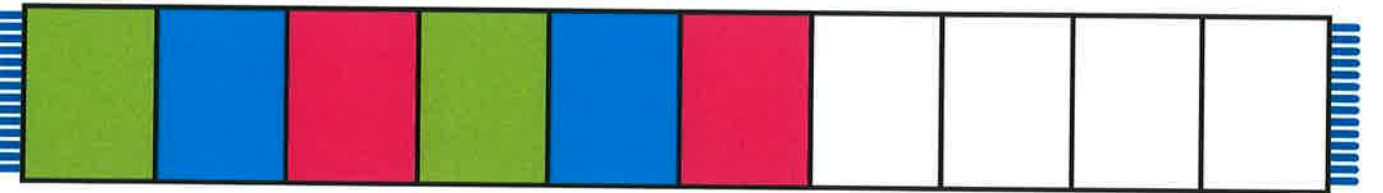
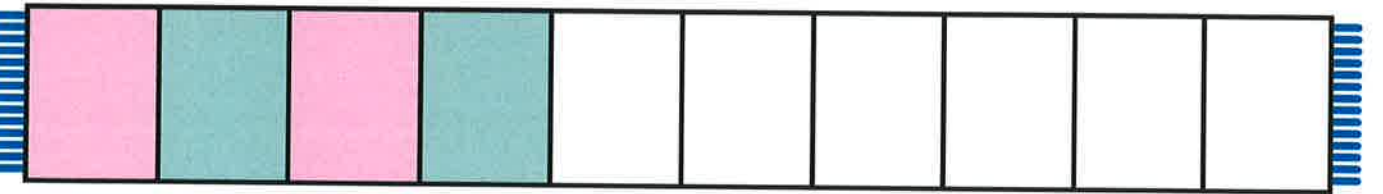
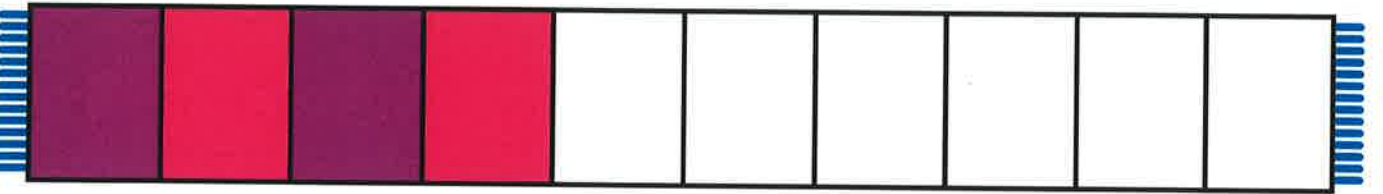
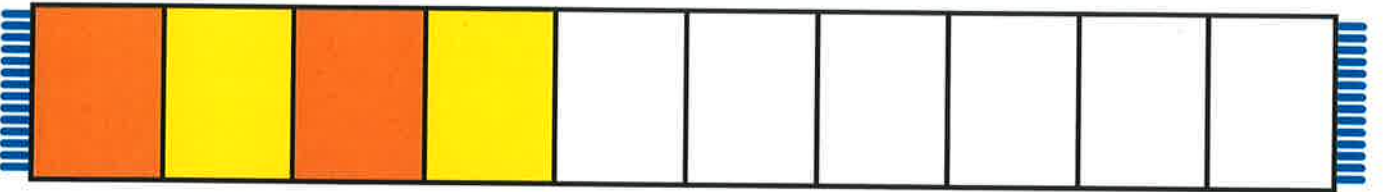
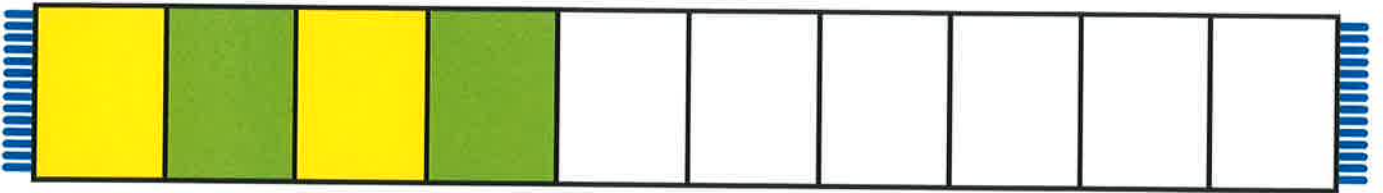
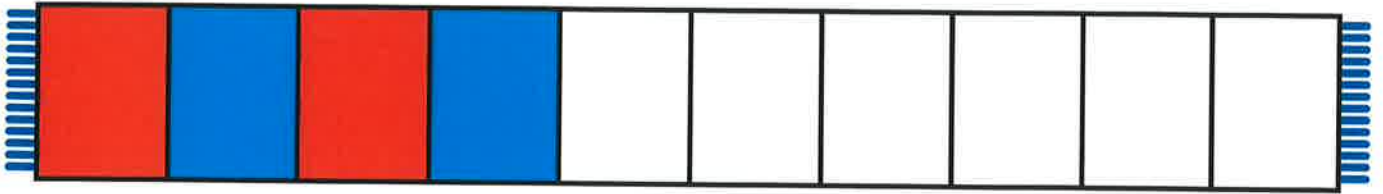





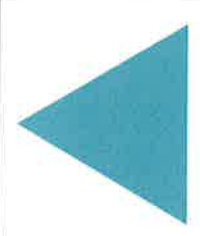

Repeating Patterns

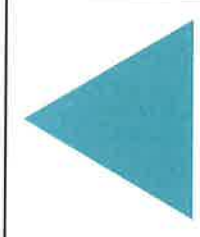
Complete the sequence below.

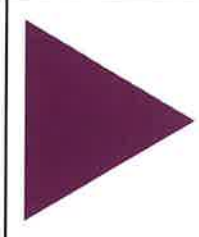

2D Shape Repeating Patterns

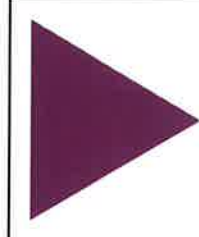
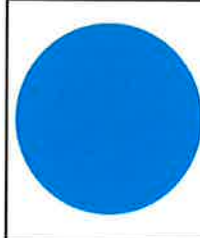
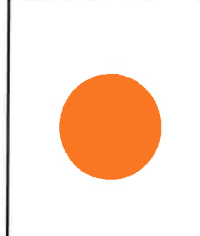
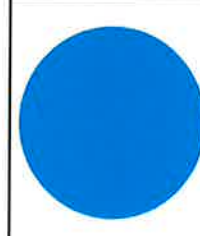
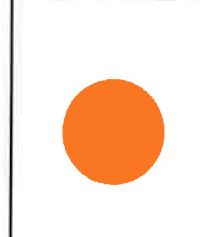
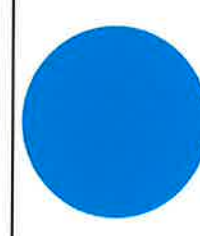
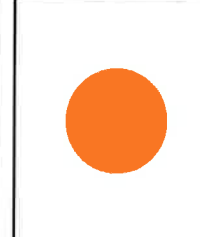
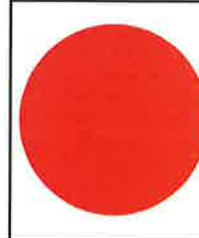
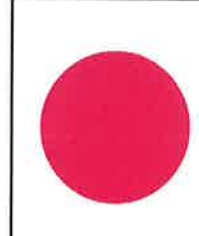
Can you complete the patterns? What shapes can you see?

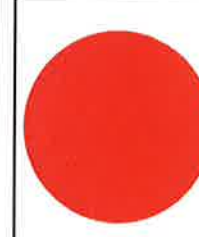
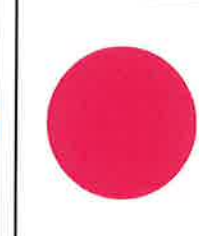
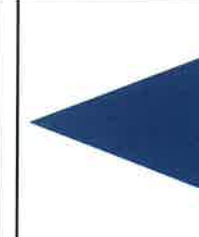





							
							
							
							

Mastery

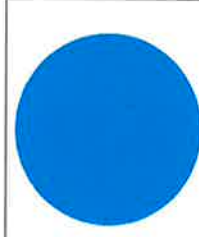

visit [twinkl.com](https://www.twinkl.com)

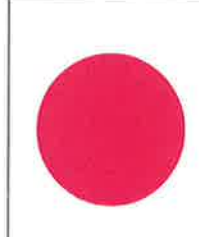
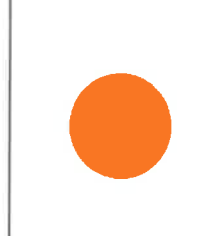



							
---	---	---	---	--	---	---	---

Repeating Patterns

Can you continue the patterns below?



1.

																			
---	---	--	--	--	--	--	--	--	--	--	--	--	--	--	--	--	--	--	--

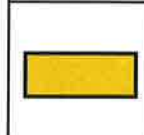

2.

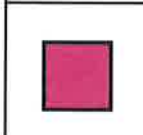
																			
---	---	--	--	--	--	--	--	--	--	--	--	--	--	--	--	--	--	--	--

3.

																			
---	---	---	--	--	--	--	--	--	--	--	--	--	--	--	--	--	--	--	--

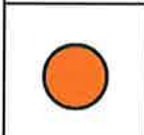
4.

																			
---	---	---	---	--	--	--	--	--	--	--	--	--	--	--	--	--	--	--	--

5.

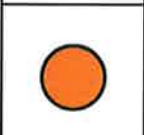
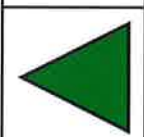
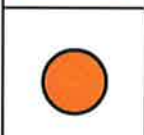
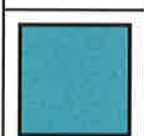
																			
---	---	---	---	---	--	--	--	--	--	--	--	--	--	--	--	--	--	--	--

Repeating Patterns Answers

Can you continue the patterns below?

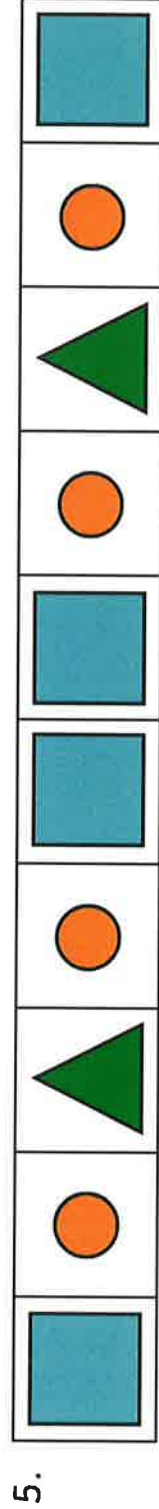
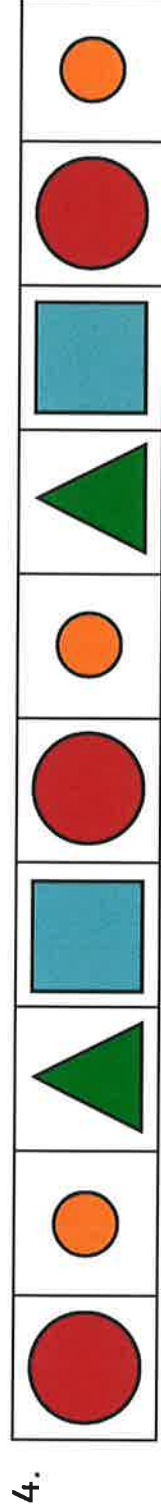
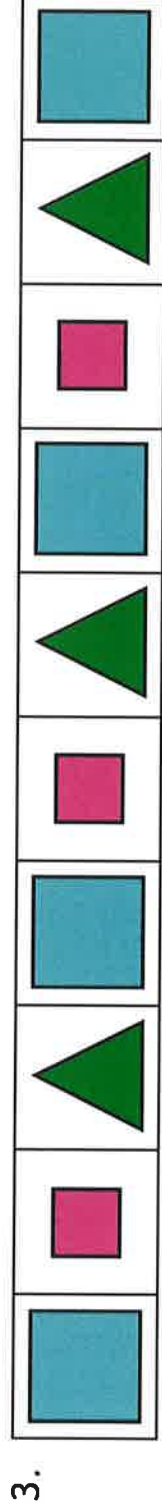
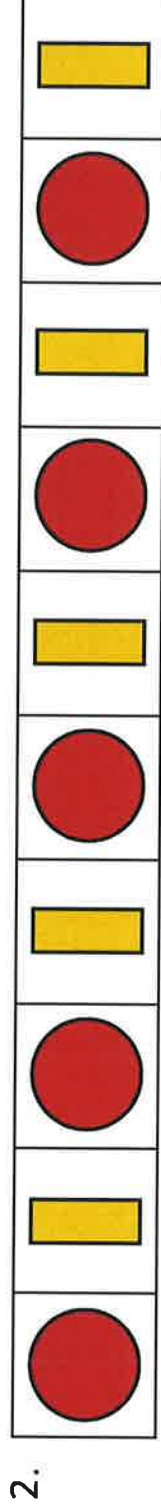
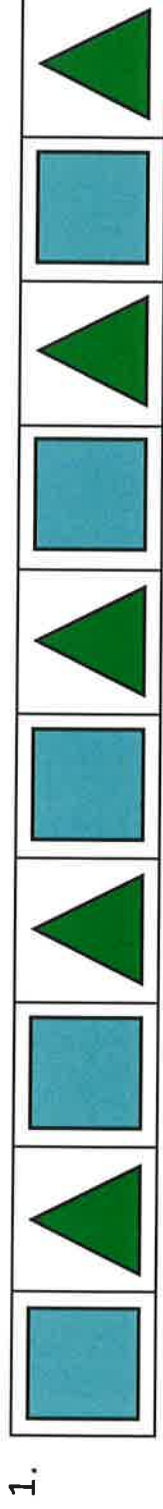

This rhyme about the seasons will help your child tune into the sounds of words and notice how they share many of the same sounds. It's also a great 'warm up' for our next activity!

Spring is showery, flowery, browery,

Summer is boppy, croppy, poppy,

Autumn is breezy, freezy, sneezy,

Winter is slippy, drippy, nippy.

Together, can you think up other words that sound the same?

Don't worry if it's a made-up word like *browery* – just help your child love the sound of words. That's what makes 'easy peasy, lemon squeezy' such fun to say.

Then your child can have fun saying real words and then coming up with lots of other 'words' that sound the same. The more they play with words, the better their vocabulary will become. And the more words they know, the better they will learn to read and write.

Watch Olive having fun squelching around in a little, boggy stream and making up words to describe what she's doing. See if you can hear all the words she is saying and say them with her. Her cousin Tala also joins in. [Click here.](#)



Now Max wants to join in the fun!

Here I am at the beach having a **lick** of my ice-cream. On my walk, I found a **stick**. What do you notice about these two words: **lick** and **stick**?

Yes, the end of the words sound the same, which makes them rhyme. In this game, if you think the words rhyme, then jump across the golden river.



How to play the game:

You'll need a piece of fabric or a skipping rope to be a 'Golden River'. Place the 'golden river' across the floor (outdoors if possible).

- **Ask your child to say:** "Farmer, farmer may I cross your Golden River?"
- You select one word from the choices below (e.g. *stick*) and say: "Not unless your word rhymes with '**stick**'."
- Your child then says their word and, if it rhymes with **stick**, you let them jump the water.
- Then it's your turn to jump across so help your child choose a word you have to find a rhyme for. Don't forget, it's the sound of the word not the spelling that matters.



Here's another set of words to play with:



The sounds right rhyme game

Decide which words sound the same and colour their boxes in with the same colour. Or you could put the same shapes next to them, like triangles.

sack

brick

rock

check

Jack

truck

sick

sock

neck

trick

lick

duck

chick

Monday 1st March - Trim & Stick in book.



The pig and the fox go
down the road.



The cow and the goat go
to the park.



The dark shark has
sharp teeth.

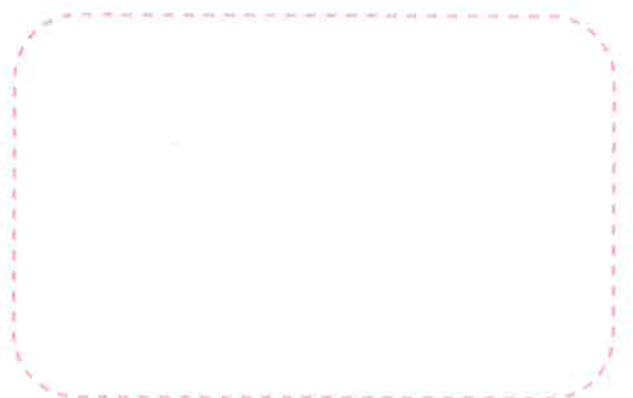

The red fish
has a big tail.



A duck, a sheep and a
goat go to see the vet.



The fat toad is
in the boat.

Counting and Matching Puzzle



shop

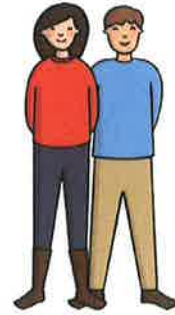

shop assistant

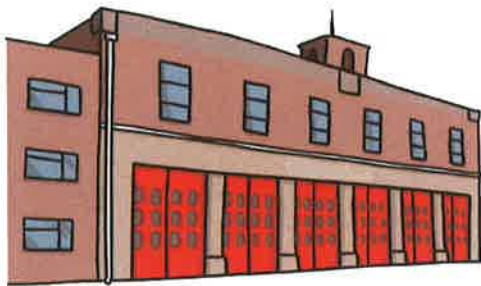

fire station



fire fighter

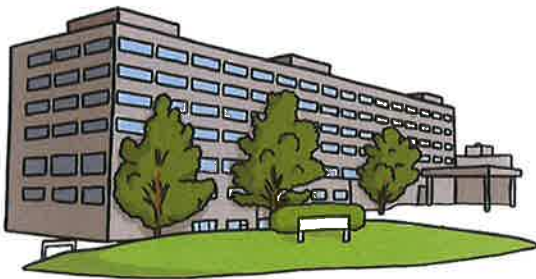

hospital



doctor/nurse



dental surgery



dentist

Counting and Matching Puzzle



post office



post deliverer



library



librarian



police station



police officer

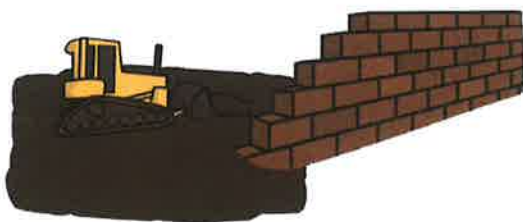

building site



builder

Counting and Matching Puzzle



school



teacher

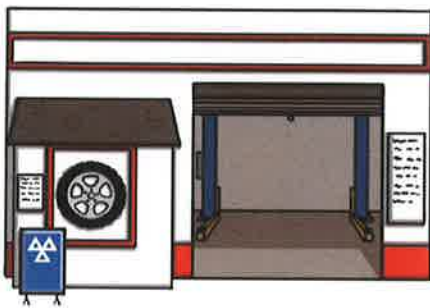

car shop



mechanic



school



lunchtime supervisor



swimming pool



lifeguard

3D Shapes Around You

Name _____

We see...

What it looks like...

cube

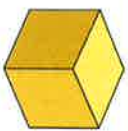

- 6 flat surfaces
- 12 edges
- 8 vertices - **CORNERS**
- all edges are the same

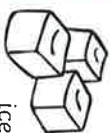

ice cubes



cardboard box



blocks

cuboid



- 6 flat surfaces
- 12 edges
- 8 vertices
- not all edges are the same



suitcase



rubber



book

square-based pyramid

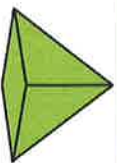

- 5 flat surfaces
- 4 triangular faces
- a sharp point
- a square base



pyramid candle



Egyptian pyramids

sphere



- perfectly round
- no edges
- no vertices



football



earth



marbles

cylinder



- 2 flat surfaces
- 1 curved surface
- 2 curved edges



candle



marker pen



mug

cone



- 1 flat surfaces
- 1 curved surface
- a point



ice cream cone



traffic cone



party hat

Tuesday 2nd March - Trim & Stick in book.

3D Shape Hunt

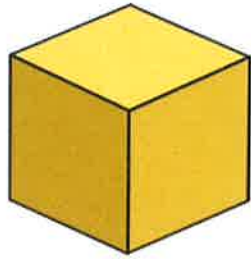

Cube

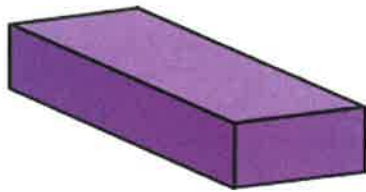

Cuboid



Cone

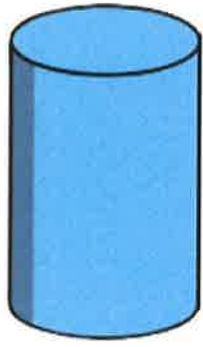

Cylinder

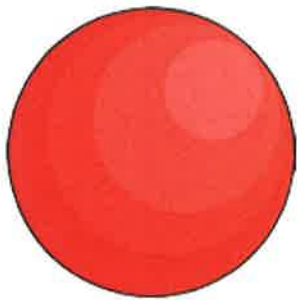

Sphere

Tuesday 2nd March

Your journey stick adventure



Find a stick and take it with you on a short walk. See if you can find some interesting things to fasten to your stick. Then use your stick and the things that you have found to talk about where you went on your walk, what you saw and how you felt.

Long ago, people in many countries used story sticks to help them tell other people the story of their journey when they returned. Objects were attached to the stick in the order in which they are found and colours represented how they were feeling.

Find a stick (a broom handle or a garden cane etc) and some coloured wool, string or ribbon. If you are unable to access a garden or go for a walk, then use your home or a room.

As you walk around, encourage your child to collect things that represent that room or space, or that interest them. Attach them to the stick in the order in which you find them. So, you might find a picture or a sock! If you're outdoors it could be a leaf or a feather.

After your walk, talk about where you went and what you found.

You can find more idea from The Woodland Trust using the link below:

<https://www.woodlandtrust.org.uk/blog/2020/03/kids-nature-activities-self-isolation/>



My Stick Adventure

We went to...



We saw...



We heard...

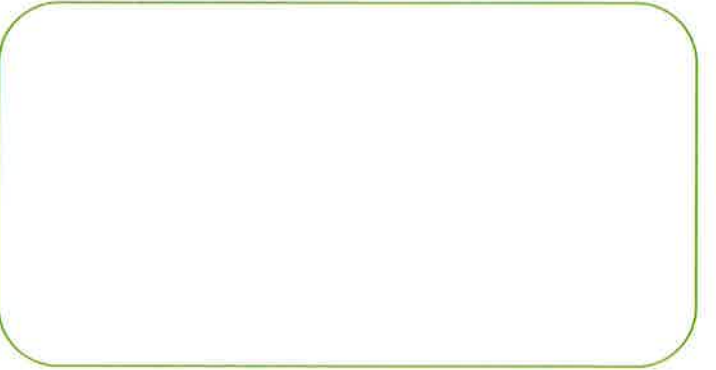

I felt.....



Story Key Words

Where did we go?

park river town forest
field path track

What did we see?

birds fish tree nest dog
horse cow mud puddles

What did we hear?

birds cars planes wind
dogs cows

How did I feel?

happy excited warm cold
tired

I Spy and Read

Draw a line to the matching picture when you have read each word.

surf



owl



boil



tears



town

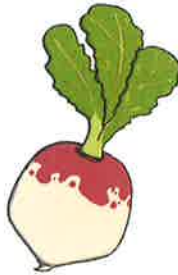

coins

COW



ear

Challenge: Can you spell a word to match one of the pictures?

Do not stick in book - tick the words you can sound out & read. Circle any words you find tricky.

Tuesday 2nd March

e ar

d ear

f ear

h ear

g ear

n ear

t ear

y ear

r ear

b ear d

Maths Mastery Home Learning Challenge

Adult Guidance

What Are We Learning?

We are learning how to name and describe 3D shapes.

How to Set up the Challenge

- Make a collection of 3D shapes from your home, such as a tin of food (cylinder), a ball (sphere), a dice (cube), a cereal packet (cuboid) and an ice cream cone (cone).
- Make a simple ramp.

How to Get Your Child Thinking

- Do you know the names of these 3D shapes?
- Can you tell me about the shapes?
- How are they the same? How are they different?
- Which shapes do you think will be good at rolling? Why?
- Which shapes have curved surfaces? Which shapes have flat faces?
- Which shapes rolled? Why did they roll? Why didn't these shapes roll?
- What have you learnt about shapes that roll?



Does It Roll?

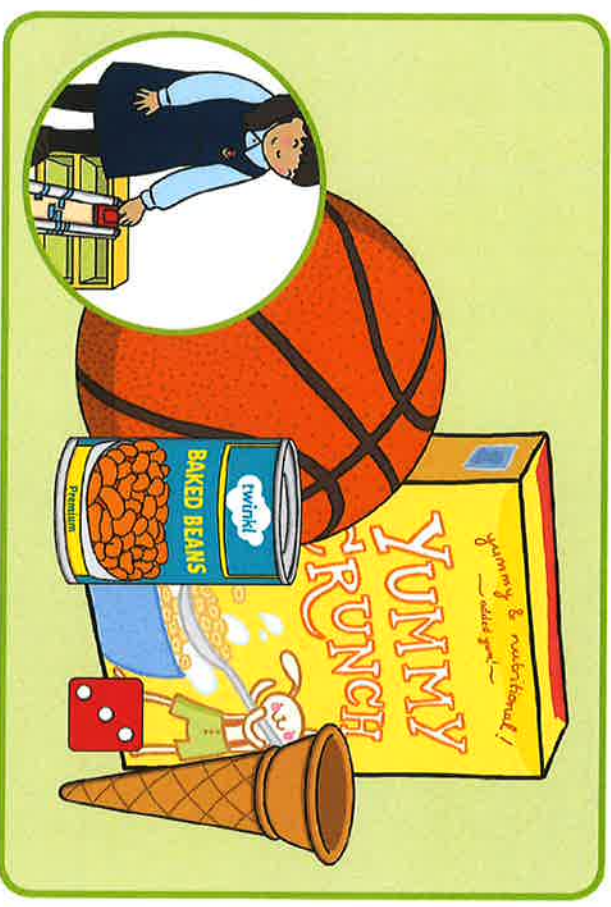

- Look at the different objects. Can you name which 3D shapes they are?
- Which shapes do you think will roll down the ramp?
- Test the shapes by placing them at the top of the ramp.
- Which shapes rolled?

Wednesday 3rd March Cut and Stick one completed table in your books

Developing

Which shapes roll?	Which shapes slide?

Secure

Curved Sides	Straight Sides

My ideas for a new story!



Can you think of places for me to visit and things for me to find in a new story? Or choose a different dog or toy who can be the hero of your story.

Now we've explored Max's story, we're going to invent a new one! It could be about Max, or you could use a dog you own or know - real or imaginary to be the hero of your story!

First, talk about where your hero might go. You can use your locality -places you know well like school, shops, playground, park, Grandpa's house etc., as well as ideas from other stories that you may know.

Next, talk about the different things your hero could find. In the story we began with, Max found sticks but in your story what could your hero find? (Fruit, toys, coins, pebbles, gold!) How could we describe them? (A red apple, a shiny coin, a round pebble, glistening gold.)

Start by drawing your ideas and talk your ideas through with your helper.

Where might your hero go?

What might your hero find?

Now decide where your story starts and end.

Now draw pictures from your new story to form a 'story map' using the story mountain on the next page to help you.

Mrs. Brown's example story

My Day at the Park

Max went to the park. It was a hot day.

He went past a big tree and saw a nest.

An egg had dropped on the grass. Max sniffed the egg.

It was big and round.

He barked to Mrs. Brown. She helped to carefully put the egg back in the nest.

Max and Mrs. Brown went home and had a cup of tea and snack.



Story Map

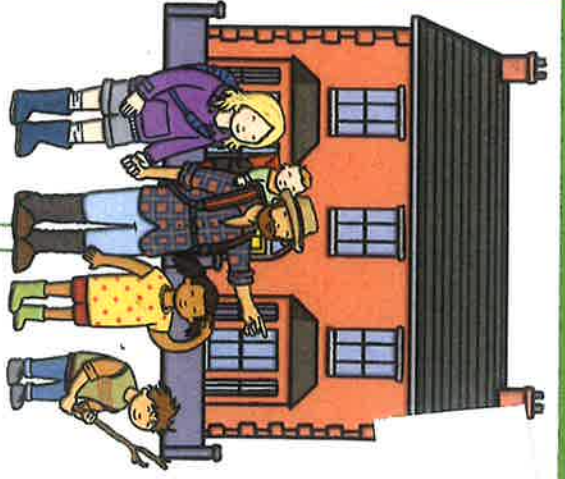

1

Blank box for writing the first part of the story.

Four horizontal lines for writing.



2

Blank box for writing the second part of the story.

Four horizontal lines for writing.

3

Blank box for writing the third part of the story.

Four horizontal lines for writing.

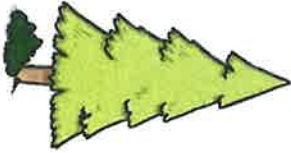

4

Blank box for writing the fourth part of the story.

Four horizontal lines for writing.

5

Blank box for writing the fifth part of the story.

Four horizontal lines for writing.



Wednesday 3rd March - Tick which sentences you can read.
Circle any words you found tricky. Do not stick in books.

Phase 3 - Week 8 - Monday - Apply

Did the shark feel
fear?

Phase 3 - Week 8 - Monday - Apply

Can a toad hear?

Phase 3 - Week 8 - Monday - Apply







Is the church near the park
or the farmyard?

↖ Split this word
into two. Eg. Start with farm

by covering yard with your finger.

3D Shape Properties Table

Look carefully at the properties of these 3D shapes. Write your results in the table.

3D Shape	Number of Straight Edges	Number of Curved Edges	Number of Vertices (corners where 2 or more sides meet)	Does it roll?	Does it Stack?
 Cube					
 Cylinder					
 Sphere					
 Cuboid					
 Cone					
 Square-Based Pyramid					

What do your results tell you about the shapes? _____

Thursday 4th March - Firm a stick in book,

3D Shape Properties Table

Look carefully at the properties of these 3D shapes.
Write your results in the table.

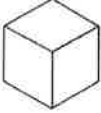
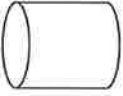
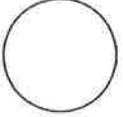
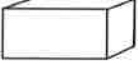
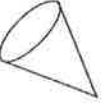
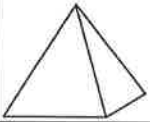
3D Shape	Number of Straight Edges	Number of Curved Edges	Number of Vertices	Does it roll?	Does it Stack?
 Cube	12	0	8	No	Yes
 Cylinder	0	2	0	Yes	Yes
 Sphere	0	0	0	Yes	No
 Cuboid	12	0	8	No	Yes
 Cone	0	1	1	Yes	No
 Square-Based Pyramid	8	0	5	No	No

The results tell me that many 3D shapes have different properties. However, a cube and a cuboid have similarities because they both have the same number of vertices and edges. Also, a cylinder is the only 3D shape that can both stack and roll.

Thursday 4th March

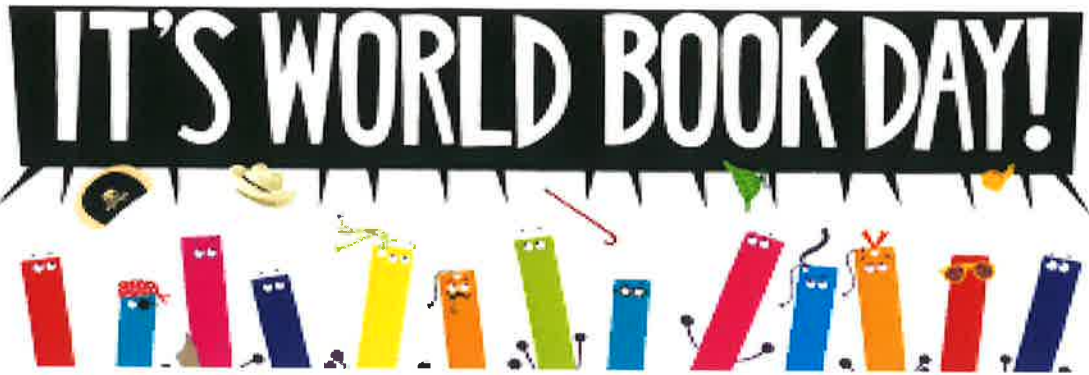

Thursday 4th March is World Book Day 2021!

Lockdown won't stop us! We will continue to celebrate our love of reading! Dress up as your favourite book character and don't forget to Tweet us pictures of your fabulous costumes. All the staff will be joining in as usual.

There are all sorts of activities going on so please look at the World Book Day website for ideas:

www.worldbookday.com

Head over to 'Share a Story Corner' and listen to some books read aloud by their author, or watch videos from the 'Author and Illustrator Academy' which has lots of exciting challenges and activities from the likes of Tom Fletcher and Katherine Rundell, to make reading even more fun and interactive.

As always, we will be holding a HEPS competition. This year, your challenge is to decorate an egg as a character of a well-known story. You can present your egg in a scene if you wish or just present it in an eggcup. Tweet your competition entries by 9am Friday 5th March and we'll let you know the winner on Twitter by the end of the day.



We are hoping our World Book Day £1 vouchers will arrive in time to go home with the next home learning packs on Friday 5th March, or if lockdown ends, we can give them out at school. You can exchange these for the £1 World Book Day books at supermarkets, including our local Tesco. It looks like there are some great choices this year!



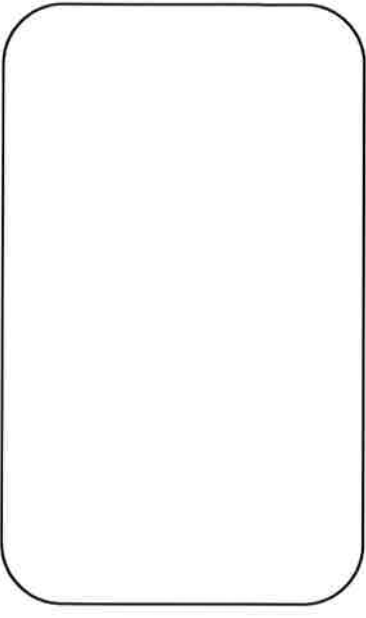

1. _____ went to the _____.

It was a _____ day.

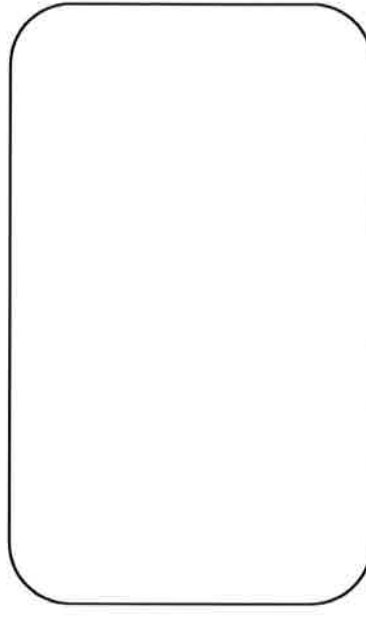

2. He went past a _____ and

saw _____.

3. _____ saw _____ on

the ground. It was _____

and _____.

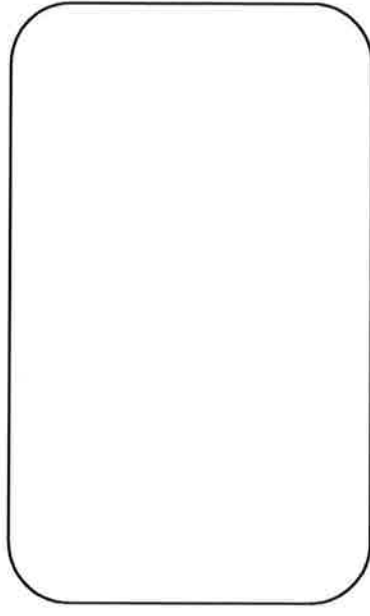

4. _____ barked to _____.

They _____

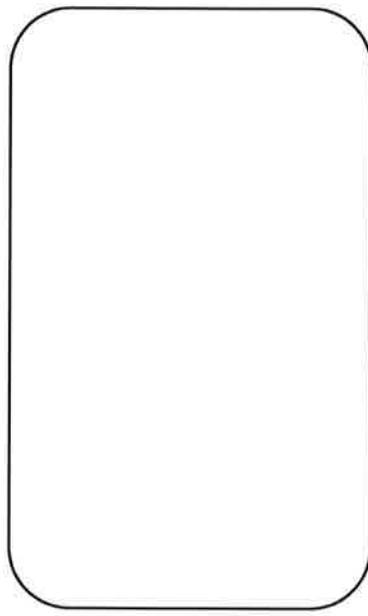

5. _____ *went home*

and _____.

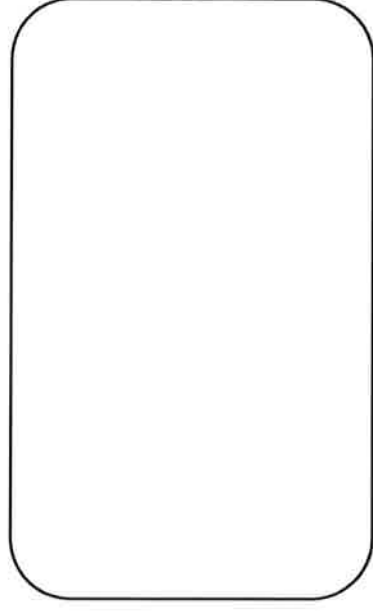

Friday 5th March - Tick which sentences you can read. Circle any words you find tricky.

Phase 3 - Week 8 - Tuesday - Apply

Do I need to cut his
hair?

Phase 3 - Week 8 - Tuesday - Apply

Put that pair of socks on
the chair.

Phase 3 - Week 8 - Tuesday - Apply

He went back to his
lair.

'air' Spelling Activity

1. Trace over 'air'.

air air air air air
air air air air air

2. Just add 'air'.

write in ^{books} ~~books~~ as there is more space.

h_ _ _

ch_ _ _

p_ _ _

f_ _ _

_ _ _



3. Write the correct 'air' words under the pictures.



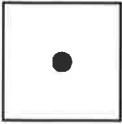
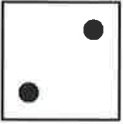
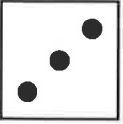
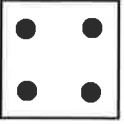

Friday 5th March

Phase 3 Roll and Read - air

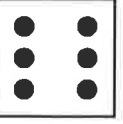
	chair	pair	air	fair	hair
	lair	chairs	pairs	fairs	lair
	pair	fair	lair	pairs	lair
	chair	lair	air	pairs	hair
	pair	chairs	fair	fairs	lair
	fairs	air	lair	hair	pair

'ear' Spelling Activity

1. Trace over 'ear'.

ear ear ear ear ear
ear ear ear ear ear

2. Just add 'ear'.

Write word in boxes where you have more room.

h---

g---

b___d

f---

y---

3. Write the correct 'ear' words under the pictures.

