

Northmoor Year 3 Lockdown English work: Week 4

|                |  |
|----------------|--|
| Monday 25.1.21 |  |
| Reading        | <p>This week's teaching focuses on 'King Kafu and the Seasons' Part 1 from <i>Bright Sparks</i>.</p> <p>(Text Outline: The first part of a short story about a familiar character - King Kafu. The King's chef discovers some pockle-berries in the garden and bakes a tart with them. The King demands to have a pockle-berry tart every day, but autumn arrives and the chef cannot find any more pockle-berries growing on the bush! Children learn that the seasons and associated weather affect how plants grow and when they bear fruit.)</p> <p>Complete the activities on <b>pages 17-18</b> of your workbooks. These activities focus on words from the text and are designed to build vocabulary.</p> |
| Spelling       | <p>Practise the following vocab. from the text:</p> <p>pockle-berry<br/>bush<br/>colourful<br/>seasons</p>   |
| Handwriting    | Copy page 18 in your neatest handwriting.  |
| Writing        | <p>The text you are focusing on this week is a short story. It is important that today you read through the story (part 1) to become really familiar with the story.</p> <p>Can you 'magpie' (borrow super ideas/words) from the text? This will help you later when you write your own story. Make a list of these in your English book as we normally do in class. Can you find anymore superb vocabulary from a dictionary or thesaurus (if you have them) that you might want to use later in your writing.</p>  |

|                 |   |
|-----------------|---|
| Tuesday 26.1.21 |   |
| Reading         | <p>Look at 'King Kafu and the Seasons' Part 1 from <i>Bright Sparks</i> and record your thoughts about the looking, clue and thinking questions on <b>page 19</b> of your workbook. The three questions are:</p> <ul style="list-style-type: none"> <li>•Looking: What are pockle-berries?</li> <li>•Clue: How does King Kafu feel when he is told there are no more pockle-berries?</li> <li>•Thinking: What questions would you ask Chef about his journey to find pockle-berries?</li> </ul> |
| Spelling        | <p>Practise the following vocab from the text:</p> <p>although<br/>though<br/>enough<br/>tough<br/>trouble<br/>double<br/>plough<br/>dough</p>  |
| Writing         | Today you are going to plan out your own adventure story. I would like you  |

|  |  |
|--|--|
|  | <p>to be inspired by King Kafu and the amazing journey that he sends his chef on.</p> <p>I would like you to choose:</p> <ul style="list-style-type: none"> <li>• A destination (this can be real or imaginary)</li> <li>• Your main characters</li> <li>• What it is that they are going to retrieve from your far-away land? It could be treasure, ingredients, a vital potion etc.</li> </ul> |
|--|--|

|                      |  |
|----------------------|--|
| Wednesday<br>27.1.21 |  |
| Reading              | <p>Today is Day 3. Can you share what you have read so far with an adult like we would in class? Ask questions such as: What are pockle-berries? How does King Kafu feel when he is told there are no more pockle-berries? What questions would you ask Chef about his journey to find pockle-berries?</p> |
| Spelling             | <p>Practise your weekly spellings.<br/>Choose the next few spellings and begin to learn them in your own style. You are wonderful at this because we have spent time working out the best way we learn for ourselves.</p>  |
| Writing              | <p>Today you are going to use your plan, as well as King Kafu and the Seasons as your inspiration.<br/>Draft the <b>first paragraph</b> today. Please remember; sophisticated vocabulary, accurate punctuation and interesting settings and characters. Read through at the end and edit and improve.</p>  |

|                  |  |
|------------------|--|
| Thursday 28.1.21 |  |
| Reading          | <p>Complete the activity on <b>page 20</b> of your workbooks. Working with an adult or partner at home discuss how the conversation on Day 3 has informed your understanding of the text, making notes in the spaces provided in your workbook.</p>  |
| Spelling         | <p>Practise your spellings.</p>  |
| Writing          | <p>Today you are going to use your plan, as well as King Kafu and the Seasons as your inspiration.<br/>Draft the <b>second paragraph</b> today. Please remember; sophisticated vocabulary, accurate punctuation and interesting settings and characters. Read through at the end and edit and improve.</p> |

|                            |   |
|----------------------------|---|
| Friday 29.1.21             |   |
| Reading                    | <p>Complete the follow-up writing activity on <b>page 21</b> of your workbooks.</p>   |
| Spelling                   | <p>Ask your parent/carer to test you on your common exception words<br/>These can be recorded in your english book.</p>   |
| Writing and<br>handwriting | <p>Today you are going to use your plan, as well as King Kafu and the Seasons as your inspiration.<br/>Draft the <b>third paragraph</b> today. Please remember; sophisticated vocabulary, accurate punctuation and interesting settings and characters. Read through at the end and edit and improve.</p> |

*Tuesday*

## Multiply 2-digits by 1-digit (2)



- 1 There are 23 marbles in a jar.

There are 5 jars.



| Tens | Ones |
|------|------|
|      |      |
|      |      |
|      |      |
|      |      |
|      |      |

How many marbles are there in total?

$5 \times 3$  ones =

$5 \times 2$  tens =

+  =

$5 \times 23 =$

There are  marbles in total.

- 2 Work out  $4 \times 15$

| Tens | Ones |
|------|------|
|      |      |
|      |      |
|      |      |
|      |      |

$4 \times 5 =$

$4 \times 10 =$

$4 \times 15 =$

- 3 Complete the multiplications.

a)  $4 \times 24 =$

b)  $3 \times 17 =$

c)  $3 \times 25 =$

d)  $34 \times 4 =$

- 4 Complete the column multiplications.

| Tens | Ones |
|------|------|
|      |      |
|      |      |
|      |      |
|      |      |

$$\begin{array}{r} \text{T} \quad \text{O} \\ 2 \quad 4 \\ \times \quad 3 \\ \hline \end{array}$$

Wednesday

Divide 2-digits by 1-digit (1)

White Rose Maths

1 There are 84 pencils to be shared equally into 4 pots.

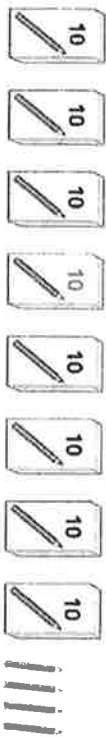

a) Draw the pencils on the place value chart to show how they are shared.

| Tens | Ones |
|------|------|
|      |      |
|      |      |
|      |      |
|      |      |
|      |      |

b) Complete the number sentences.

8 tens  $\div$  4 =  tens

4 ones  $\div$  4 =  one

84  $\div$  4 =

c) How many pencils are in each pot?

2 Use a place value chart to work out the calculations.

a)  $39 \div 3 =$

b)  $68 \div 2 =$

3 Amir solves  $48 \div 2$  on a place value chart.

| Tens | Ones |
|------|------|
|      |      |
|      |      |
|      |      |

Complete the part-whole model to show what Amir has done.

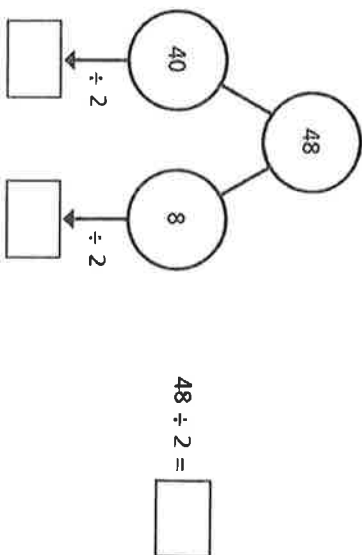

4 Work out the divisions.

a)  $69 \div 3 =$

b)  $66 \div 2 =$

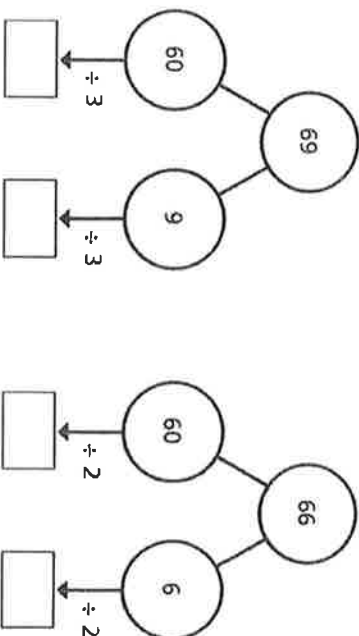

# Instruments of the Orchestra

## The String Family

Instruments in the string family have four strings. They can be played using a bow or plucked using fingers. The note is changed by pressing down on the string in different places on the neck of the instrument.

Label the instruments from the string family.

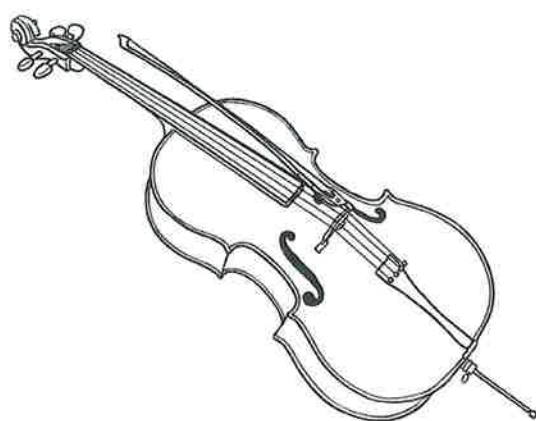
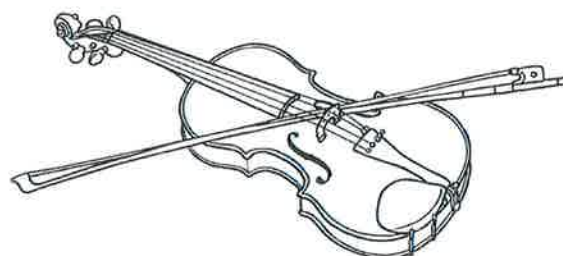
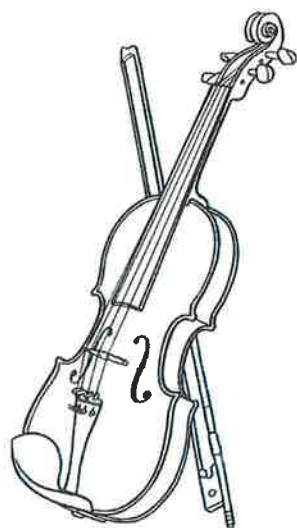

# Queen Victoria

## Information

Queen \_\_\_\_\_ was born in the year \_\_\_\_\_. She was born into a \_\_\_\_\_ family. Her father was \_\_\_\_\_ and he died in \_\_\_\_\_.

Queen Victoria became Queen after her \_\_\_\_\_ died. She was crowned Queen in \_\_\_\_\_.

She married someone called \_\_\_\_\_ who was also her \_\_\_\_\_.

She had \_\_\_\_\_ children. \_\_\_\_\_ were sons and \_\_\_\_\_ were daughters.

She was Queen to a very large empire. Countries in this empire were \_\_\_\_\_, \_\_\_\_\_, \_\_\_\_\_ and \_\_\_\_\_.

Her husband, Albert died in \_\_\_\_\_ so the Queen wore \_\_\_\_\_ clothes for the rest of her \_\_\_\_\_.

The Queen died in \_\_\_\_\_.

## Words to choose from

cousin Edward India 1838 five 1819 Jamaica uncle four 9  
Victoria 1820 1861 Albert New Zealand Canada royal black life 1901

# What did you see?

Please circle the number that shows the most of each species that you **see together at the same time**. Write the number in the space provided if you see more than 10.

Your name \_\_\_\_\_



**Blackbird**

1 2 3 4 5  
6 7 8 9 10

More than 10 \_\_\_\_\_



**House sparrow**

1 2 3 4 5  
6 7 8 9 10

More than 10 \_\_\_\_\_



**Black-headed gull**

1 2 3 4 5  
6 7 8 9 10

More than 10 \_\_\_\_\_



**Magpie**

1 2 3 4 5  
6 7 8 9 10

More than 10 \_\_\_\_\_



**Blue tit**

1 2 3 4 5  
6 7 8 9 10

More than 10 \_\_\_\_\_



**Robin**

1 2 3 4 5  
6 7 8 9 10

More than 10 \_\_\_\_\_



**Carrion crow**

1 2 3 4 5  
6 7 8 9 10

More than 10 \_\_\_\_\_



**Song thrush**

1 2 3 4 5  
6 7 8 9 10

More than 10 \_\_\_\_\_



**Chaffinch**

1 2 3 4 5  
6 7 8 9 10

More than 10 \_\_\_\_\_



**Starling**

1 2 3 4 5  
6 7 8 9 10

More than 10 \_\_\_\_\_



**Coal tit**

1 2 3 4 5  
6 7 8 9 10

More than 10 \_\_\_\_\_



**Greenfinch**

1 2 3 4 5  
6 7 8 9 10

More than 10 \_\_\_\_\_

Turn over for more birds to spot.

Please circle the number that shows the most of each species that you **see together at the same time**.  
Write the number in the space provided if you see more than 10.



**Collared dove**

1 2 3 4 5  
6 7 8 9 10

More than 10 \_\_\_\_\_



**Long-tailed tit**

1 2 3 4 5  
6 7 8 9 10

More than 10 \_\_\_\_\_



**Dunnock**

1 2 3 4 5  
6 7 8 9 10

More than 10 \_\_\_\_\_



**Pied wagtail**

1 2 3 4 5  
6 7 8 9 10

More than 10 \_\_\_\_\_



**Jackdaw**

1 2 3 4 5  
6 7 8 9 10

More than 10 \_\_\_\_\_



**Woodpigeon**

1 2 3 4 5  
6 7 8 9 10

More than 10 \_\_\_\_\_



**Great tit**

1 2 3 4 5  
6 7 8 9 10

More than 10 \_\_\_\_\_



**Wren**

1 2 3 4 5  
6 7 8 9 10

More than 10 \_\_\_\_\_

Draw any bird you have seen that isn't on this sheet.

For more information, visit:  
[rspb.org.uk/schoolswatch](http://rspb.org.uk/schoolswatch)

The RSPB is a registered charity in England & Wales 207076,  
in Scotland SC037654. Drawings by Mike Langman. 382-0338-14-15



**RSPB Wildlife Explorers**  
is the junior membership  
of the RSPB.





## What will you see?

Enjoy an hour watching nature and count the birds in your garden, local park or from your balcony.

### Take time out for nature – and you!

#### How to take part. Everyone counts!

- Count the birds for one hour in your garden, local park or from your balcony between **29 and 31 January 2021**.  
Only include those that land, not those flying over. Count the most birds you see at any one time – otherwise you could count the same bird twice.
- Submit your results by **15 February 2021**. Go to our website at [rspb.org.uk/birdwatch](http://rspb.org.uk/birdwatch), and using the code **BH30**, tell us what you saw. Remember even if you saw nothing, it still counts. The more results we receive, the better the picture we will have.

By submitting your results online, you're helping us spend more on saving nature. However, if you are unable to do so, you can print a copy of this form, complete and return it by post. Put it in an envelope and simply write **FREEPOST RSPB BIG GARDEN BIRDWATCH** on the front. Please ensure only this wording appears on the return envelope. This is a short address, but rest assured it'll reach us.

| Name of bird    | Most seen at one time    |
|-----------------|--------------------------|
| Blackbird       | <input type="checkbox"/> |
| Blue tit        | <input type="checkbox"/> |
| Chaffinch       | <input type="checkbox"/> |
| Coal tit        | <input type="checkbox"/> |
| Collared dove   | <input type="checkbox"/> |
| Duncock         | <input type="checkbox"/> |
| Goldfinch       | <input type="checkbox"/> |
| Great tit       | <input type="checkbox"/> |
| Greenfinch      | <input type="checkbox"/> |
| House sparrow   | <input type="checkbox"/> |
| Long-tailed tit | <input type="checkbox"/> |
| Magpie          | <input type="checkbox"/> |
| Robin           | <input type="checkbox"/> |
| Starling        | <input type="checkbox"/> |
| Woodpigeon      | <input type="checkbox"/> |
| Other birds     | <input type="text"/>     |
|                 | <input type="text"/>     |

Discover more: [rspb.org.uk/birdwatch](http://rspb.org.uk/birdwatch)

The survey results will be announced on our website in April. Don't forget to share how you got on **#BigGardenBirdwatch**

### Let's keep in touch – on your terms

**Thank you for caring about nature.** We're determined to do all we can to save it. You're a very important part of that which is why we'd love to let you know about the conservation, campaigning, research and fundraising work that we're doing.

If you're happy for the RSPB and RSPB Shop to keep in touch, please let us know how you would like to hear from us:

|       | Yes                      | No                       |   |
|-------|--------------------------|--------------------------|---|
| Post  | <input type="checkbox"/> | <input type="checkbox"/> | Please tick "yes" or "no" for each option to ensure your form is valid. |
| Phone | <input type="checkbox"/> | <input type="checkbox"/> |   |
| Email | <input type="checkbox"/> | <input type="checkbox"/> |   |
| Text  | <input type="checkbox"/> | <input type="checkbox"/> |   |

You're in control. If you'd like to change your choices at a later date, all you have to do is call us on **01767 693680** or go to [rspb.org.uk/preferences](http://rspb.org.uk/preferences). If you decide to stay in touch, we'll also keep you up to date with news about membership, products, offers and competitions.

**Your details will be kept safe and secure, only used by us, or those who work for us, and will not be shared with anyone else.** To understand our supporters better we combine and analyse the information you provide; with what we know about how you've helped us; and other external sources of data. This helps us to decide what communications will be of interest to you and save the resources we have available for our conservation work. We also use this information to run our charity's operations, e.g. if you place an order or make a donation, we'll need your details to process those.

If you would like to know more or understand your data protection rights, please take a look at [rspb.org.uk/privacypolicy](http://rspb.org.uk/privacypolicy)

Please use **CAPITAL** letters.

Title (Mr, Mrs, Miss, Ms, Mx, etc)

First name

Last name

Address

Town

County/Council area

Postcode

Telephone

Mobile

Email (over 18s only)

Date of birth (if under 18) / /

How many people took part? Adults  Children

If you didn't do the Big Garden Birdwatch at home, where did you do it?

Postcode (if different from above)

Please let us know your results by **15 February 2021**.

Submit your results online at: [rspb.org.uk/birdwatch](http://rspb.org.uk/birdwatch) using the code **BH30**. It is quick, easy and the savings made on postage and processing costs, help us spend more on conservation.